

## F1625 Site Preparation Document

---

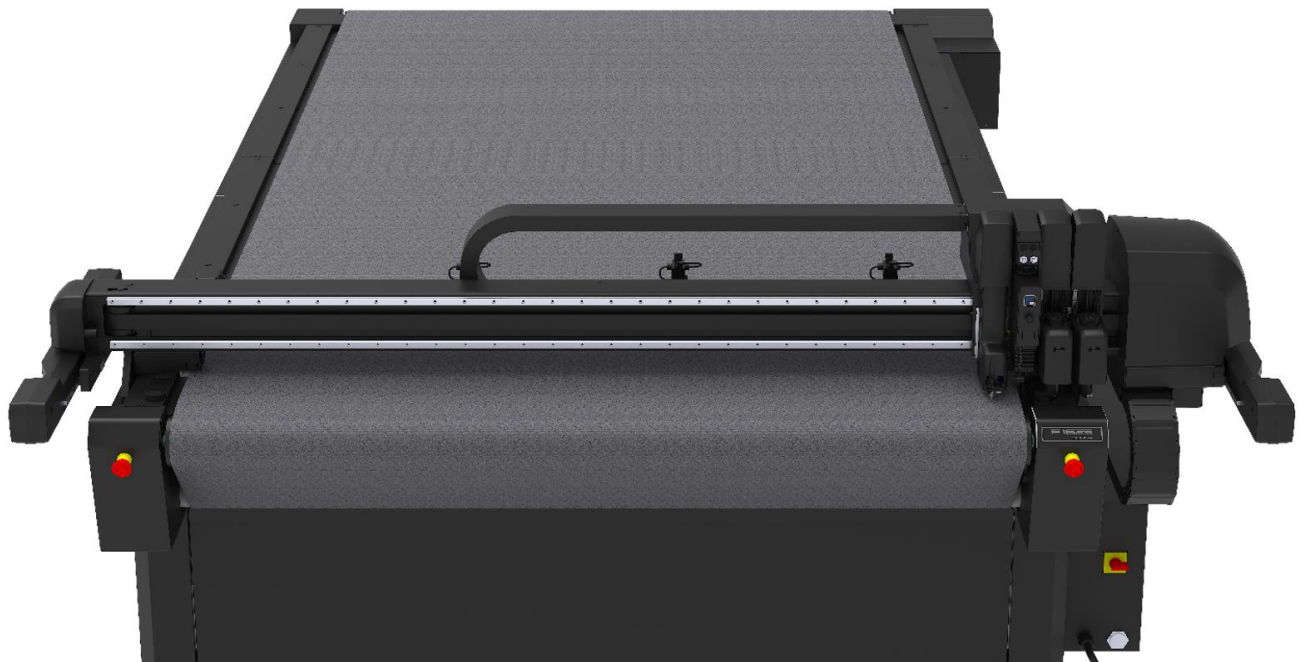

## 1. Revision History

Version	Date	Reason for modification	Author
001	10/04/2025	Original version	Sam B.
002		Added: <ul style="list-style-type: none"><li>Weights for crate and machine</li></ul>	Sam B.
003	07/08/2025	Added: <ul style="list-style-type: none"><li>Transportation specs with 1 pallet truck</li></ul>	Sam B.
004	01/10/2025	Changed: <ul style="list-style-type: none"><li>Machine weights and dimensions table naming</li></ul>	Sam B.

### Notice

Due to continuing research and product improvements, Summa reserves the right to modify the information contained in this document at any time without prior notice. Unauthorized copying, modification, distribution, or display is prohibited. All rights reserved.

Copyright © Summa

## 2. Contents of this document

This document explains how to prepare the customer site for the installation of the F-Series Flatbed Cutter and gives information regarding transportation and connection. At the end of this document, official forms are included that provide an overview of the installation site, system configuration and end-user workflow. This information will facilitate the installation.

1. Revision History .....	2
2. Contents of this document .....	3
3. Safety Precautions .....	4
4. Installation tools .....	5
5. Site Preparation .....	5
5.1 Packaging and Transportation .....	6
5.2 Floorplan .....	8
5.2.1 With Optional Routing System .....	9
5.2.2 With Sheet Feed 75 .....	9
5.3 Connections .....	10
5.3.1 USB Connection .....	10
5.3.2 Ethernet Connection .....	10
5.3.3 Electrical Connection .....	11
5.3.4 Pneumatic Connection .....	14
5.4 System requirements .....	15
6. Checklist .....	16
6.1 Packaging and Transportation .....	16
6.2 Floorplan .....	16
6.3 Connections .....	16
6.3.1 Electrical .....	16
6.3.2 Pneumatic .....	17
6.4 Installation .....	17
6.5 Workflow Information .....	<b>Error! Bookmark not defined.</b>
6.6 Conformity Declaration and Signature .....	18

## 3. Safety Precautions

---



### Risk of electric shock.

These installation instructions are for use by qualified service personnel only. Hazardous voltage is present for up to 5 minutes after disconnection of power supply. To reduce the risk of electric shock do not perform any servicing other than that contained in the operating instructions unless you are qualified to do so.

---



### Contains Class II laser.

Do not stare into the beam.

Complies with CFR Title 21, Chapter I, Subchapter J, Sections 1010.2, 1010.3, 1040.10 and 1040.11 in effect at date of manufacture.

Caution: use of any controls, adjustments, or procedures other than those specified herein may result in hazardous radiation exposure.

---



### Sharp edges.

Touching the tools with bare hands may cause injury. Do not touch.

---



### Moving parts.

Keep body parts out of the motion path. This equipment is not suitable for use in locations where children are likely to be present. This equipment is not intended for use by children.

Avoid touching the moving parts and entering the cutting area with the hands, clothing, jewellery, or hair.

Unplug this appliance if it will not be used for an extended period of time.

---



### Hot surface.

Do not touch these parts.

---



### Hearing protection.

- Hearing protection should be worn in case of prolonged exposure to the noise of the vacuum pumps.
  - Eye and/or hearing protection must be worn when using certain power tools.
-

## 4. Installation tools

Please consult the F1625-4X installation manual for a complete list of the tools that are needed for the installation.

## 5. Site Preparation

Before installing the flatbed cutter:

1. **Preparation:** Ensure the site meets the requirements listed in this document.
2. **Documentation:** Use the installation completion document and ensure all parties have a copy.
3. **Engineer Time:** Proper site preparation is crucial. Delays due to missing items or unprepared infrastructure requirements will incur additional charges.

## 5.1 Packaging and Transportation

The F Series is delivered in one crate.

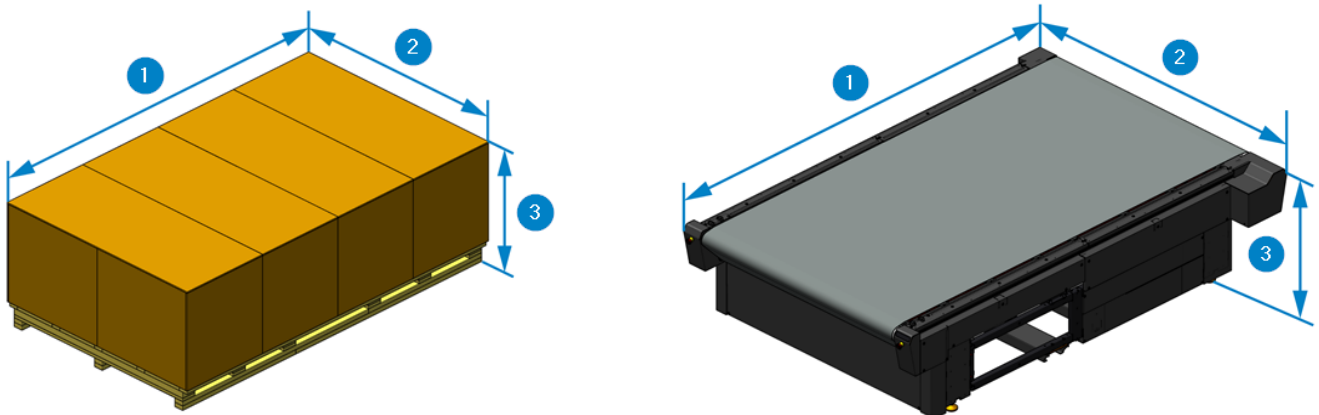

Figure 1: Crate (left) and Machine Frame (right) with Dimensions

Use the table below to determine the correct lifting capacity for unloading and transporting this crate.

	1	2	3	Weight
<b>F1625 in Crate</b>				
cm	374	223	125	±1483 kg
ft	12.24	7.3	4.1	±3269 lbs
<b>F1625 Machine Frame</b>				
cm	329	218	74	±903 kg
ft	10.8	7.2	2.4	±1991 lbs

Transportation by forklift:

- **Fork length:** minimum 1500 mm (4.9 ft).
- **Lifting capacity:** check cross reference the weight of the crate with the load capacity table of the forklift.
- **Transportation orientation:** the crate or machine can only be picked up from sides ①!
- A forklift is **mandatory** to unload the machine from the truck and lift the machine from the crate.

Transportation by pallet trucks:

Option 1:

- **Amount required:** 2 pallet trucks.
- **Length:** minimum 1 m
- **Transportation orientation:** the crate or machine can only be picked up from both sides ②!

Option 2:

- **Amount required:** pallet truck.
- **Length:** minimum 3 m
- **Transportation orientation:** the crate can only be picked up from side ②!

Points of attention:

- Consider an extra 10cm when transporting the crate/machine through corridors and doorways.
- Avoid difficult paths (stairs, steps, ramps, ...)
- The machine needs to remain as level as possible during transportation. It can and may **not be tilted!**

## 5.2 Floorplan

Use the floorplan to determine if the installation area and/or positioning is suited for the machine.

### Important information:

- Consider a minimum of 75 cm of space around the machine for operation.
- A solid and level concrete surface, preferably antistatic, is recommended.
- The height difference over the entire installation floor should not be more than 3cm.
- Wooden frames, floors or constructions are not suitable.

\* = Distance to front right emergency stop and operator should not exceed 75 cm

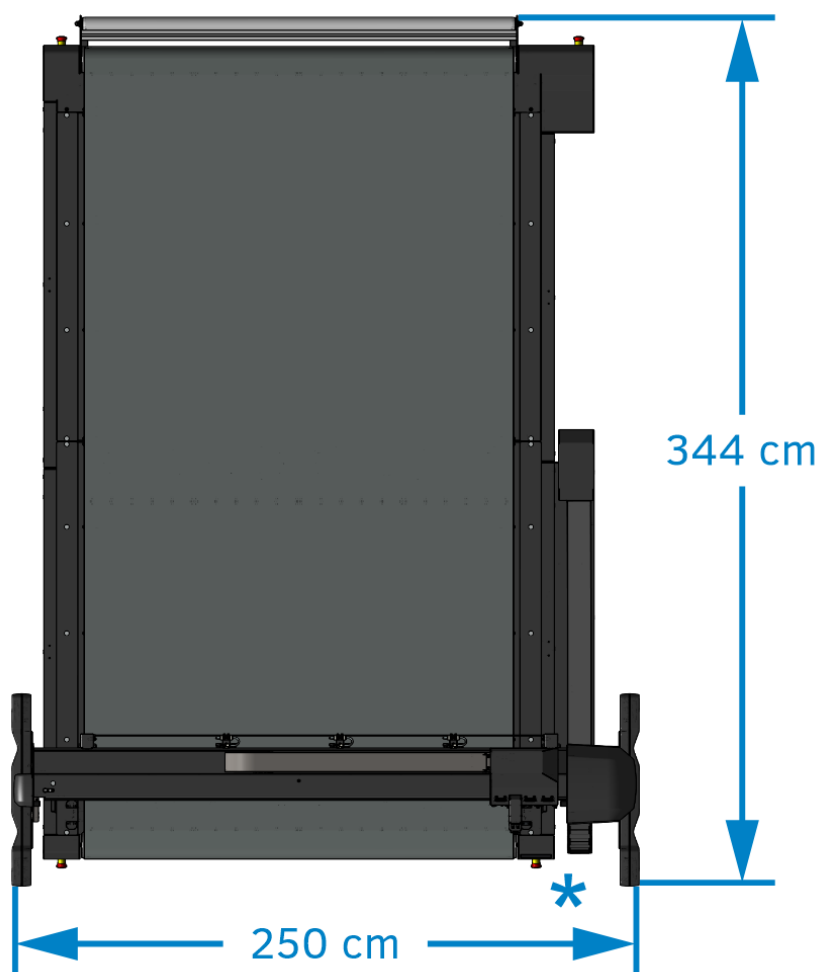

Figure 2: Floorplan – Top View

## 5.2.1 With Optional Routing System

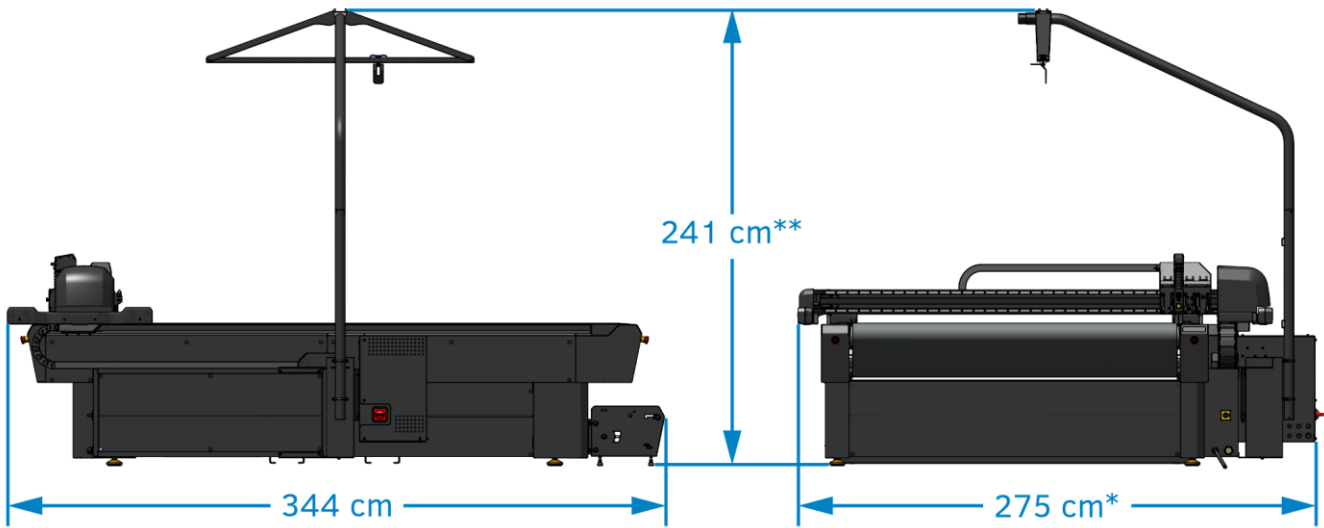

Figure 3: Floorplan – Right Side View and Front View with Routing System

\*Dimension for HF router system. Standard Router system is 260 cm wide.

\*\*Height increases by 9 cm in combination with Sheet Feed 75 or 500-9422 Leveling Kit.

Extra space at the right side is recommended to safely attach and remove the router module to the module station.

## 5.2.2 With Sheet Feed 75

Final position of the Sheet Feed 75 is determined during the installation process. This illustration is only for dimensioning purposes.

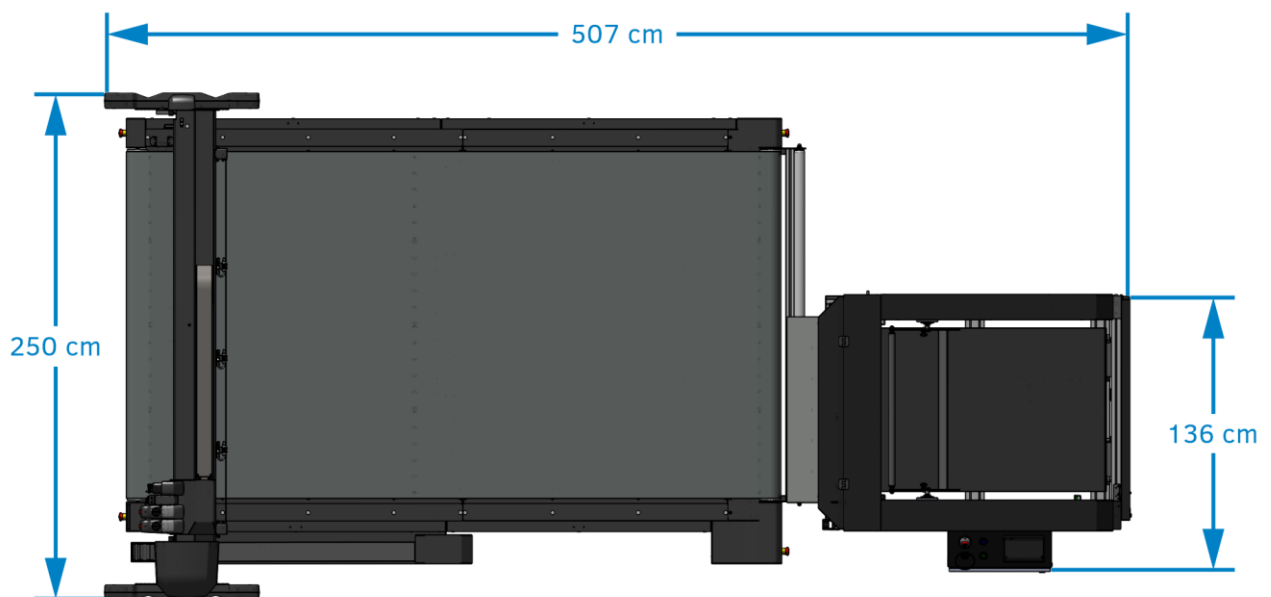

Figure 4: Floorplan – Top View with Sheet Feed 75

## 5.3 Connections

All connections are located at the front right of the machine or in close proximity.



Figure 5: Connections Location

### 5.3.1 USB Connection

The flatbed cutter is delivered with a 3-meter USB cable and a 0.5m extension USB cable for connection to the PC.

#### WHAT NOT TO USE?

- A USB cable longer than 3.5m
- (Powered) USB hubs
- Other USB extension cables

### 5.3.2 Ethernet Connection

#### With Sheet Feed 75 Option

The Sheet Feed 75 is connected with an ethernet cable to the same computer as the F1625. This requires a **dedicated** ethernet port:

- Ethernet PCIe card  
or
- USB to ethernet adaptor

An ethernet cable of 5m is included.



Figure 6: USB to ethernet adaptor (left) and PCIe ethernet card (right)

### 5.3.3 Electrical Connection

Always adhere to the local electrical requirements.

#### 5.3.3.1 F1625

Power configurations and requirements (including Summa's standard vacuum set):

Configuration	Frequency	Max Load
3 x 400V + N	50 Hz	30 A
3 x 208V + N	60 Hz	30 A
3 x 230V	50 Hz	30 A

#### Plug and Socket Requirements:

The plug and wall socket are **NOT SUPPLIED** with the machine and must be provided by the end user!

Type	IEC60309
Amperage	32 A
Poles	3P or 4P + PE (according to power)



Figure 7: IEC60309 Plug and Socket – reference picture

The connection may also be done with an electric wall box instead of a plug and socket. Check the cable requirements.

#### Cable Requirements:

The electrical cable is **NOT SUPPLIED** with the machine and must be provided by the end user!

Cable Length	Distance to wall socket + 2m
Cores	3 or 4 core + ground (according to power)
Cross Section EU	4 mm <sup>2</sup> / core Cable longer than 25m = 6 mm <sup>2</sup> / core
Cross Section North America	AWG 10 MTW rating / core 208Y/120 VAC requires external overcurrent protection of 40A max, 10kA interrupting capacity
Overall Diameter	Between 9 mm (0,36") and 17 mm (0,67")

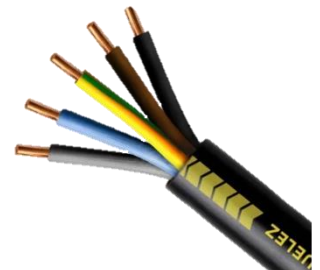

Figure 8: 5G2.5 mm<sup>2</sup> cable – reference picture

### 5.3.3.2 Sheet Feed 75 (EU only)

#### Power Configuration

Configuration	Frequency	Max Load
3 x 400V + N	50 Hz	TBD

#### Plug and Socket Requirements:

The plug and wall socket are **NOT SUPPLIED** with the Sheet Feed 75 and must be provided by the end user!

A separate power supply point needs to be provided with the following specifications:

Type	IEC60309
Amperage	16 A
Poles	3P + N + PE
Differential	500 mA type B



Figure 9: Sheet Feed 75

#### Cable Requirements:

The electrical cable is **NOT SUPPLIED** with the machine and must be provided by the end user!

Cable Length	Distance to wall socket + 2m
Cores	3P + N + PE
Cross Section EU	2.5 mm <sup>2</sup> / core Cable longer than 25m = 4mm <sup>2</sup> / core
Overall Diameter	Between 9 mm and 17 mm

### 5.3.3.3 Vacuum cleaner for all router options

Type	3 x 400V + N 50 Hz	3 x 230V 50 Hz	3 x 208V + N 60 Hz	3 x 208V 50 - 60 Hz
<b>Metabo</b>	OK	OK	Cannot be used	Cannot be used
<b>3Flow</b>	OK	OK	Cannot be used	Cannot be used
<b>Hercules</b>	OK main breaker 20A <sup>(1)</sup>	Extra socket <sup>(2)</sup>	Cannot be used	Cannot be used
<b>Delfin DM3EL</b>	Cannot be used	Cannot be used	Max 2250W <sup>(4)</sup> with: Extra socket <sup>(2)</sup> Relay 30A <sup>(3)</sup>	Max 2250W <sup>(4)</sup> with: Extra socket <sup>(2)</sup> Relay 30A <sup>(3)</sup>
<b>3rd party</b>	Max. 3000W Main breaker 20A <sup>(1)</sup> Relay 30A <sup>(3)</sup>	Max. 2400W or	Max 1500W <sup>(4)</sup> or	Max 1500W <sup>(4)</sup> or
		Max. 3000W with: Extra socket <sup>(2)</sup> Main breaker 20A <sup>(1)</sup> Relay 30A <sup>(3)</sup>	Max 2250W <sup>(4)</sup> with: Extra socket <sup>(2)</sup> Relay 30A <sup>(3)</sup>	Max 2250W <sup>(4)</sup> with: Extra socket <sup>(2)</sup> Relay 30A <sup>(3)</sup>

- (1) Models build before September 2017 may contain a main circuit breaker of 15A. If this is the case, then it has to be replaced with one of 20A (MF9017)
- (2) Extra socket means that a secondary wall socket (single phase) needs to be provided for the vacuum cleaner.
- (3) Router option boards build before September 2017 may have a relay for the vacuum cleaner of 12A. In this case, the relay needs to be changed by a relay 30A (kit 500-9346).
- (4) Specifications given for a 110V vacuum cleaner.

Specifications for third party vacuum cleaners:

- Air Output (at fan): Min 3.000l/min (106 cfm)
- Vacuum: Min 230 hPa (mbar) (92 Inch of water)
- Hose diameter is 35 – 38mm (exact specifications of connection can be found on the internet under 'screw cuff a72-84V')

## 5.3.4 Pneumatic Connection

The pneumatic tube and connector are **NOT SUPPLIED** with the flatbed cutter and must be provided by the end user!

### Pneumatic tube:

- Ø8mm
- Length: Distance between machine and compressor + 2m

### Connector:

- 1: Ø8mm connection for pneumatic tube
- 2: Thread for connection to compressor or quick coupler



Figure 10: Pneumatic Connector – Reference Picture

### Compressor:

Depending on the options, other compressor specifications may apply.

- **Standard configuration, without pneumatic tools/options:**
  - 7 bar (100 PSI) @ 20 l/min (0.72 cfm)
- **With HF router option:**
  - Particle Class 3
  - Water Class 4
  - Oil Class 3
- **With POT:**
  - 7 bar (100 PSI) @ 350 l/min (12.4 cfm)
  - Class 4 ISO 8573-1 or additional air cleaner/dryer
- **With Sheet Feed 75:**
  - 7 bar (100 PSI) @ 400 l/min (14.1 cfm)
  - Class 4 ISO 8573-1 or additional air cleaner/dryer

## 5.4 Environmental

	Ambient Temperature and Humidity	
In Operation	15 to 35 °C	59 to 95 °F
Storage	-30 to 70 °C	-22 to 158 °F
Vacuum Pump	40 °C	104 °F
Relative Humidity	35 - 75 %, non condensing	

## 5.5 Computer Requirements

Dedicated PC or laptop with hardware components that are up to date with today's standards. Do not forget to provide the computer with power and/or a network connection.

- **OS:** Windows 10/11
- **Screen:** Full HD
- **USB:** At least 1 free USB connection and an optional one (if remote has been ordered).
- **Ethernet:** Extra dedicated ethernet connection in combination with Sheet Feed 75 option



**ATTENTION:** Other Window **versions** are also available: the N edition for Europe and the KN edition for South Korea. If one of these editions is installed, the media pack has to be installed as well, to avoid camera problems. To install the media pack, go to: <https://support.microsoft.com/en-us/help/3145500/media-feature-pack-list-for-windows-n-editions>.



**ATTENTION:** It is highly recommended to use a dedicated computer to connect to the table. If other programs and services not related to driving the table are running, they can take up too many resources so that the minimum system requirements will no longer suffice.

## 6. Checklist

Complete the following checklists, sign off the certification page; scan them (or take a picture) and mail them to [installations@summa.com](mailto:installations@summa.com).

### 6.1 Packaging and Transportation

- A forklift with the correct lifting capacity will be available.
- The crate/machine can be safely unloaded and transported inside the building correctly.
- Two people are available for unpacking the machine.

There is a clear path to the installation area (stairs, steps, ramps, ...)

- Yes.
- No: \_\_\_\_\_

### 6.2 Floorplan

- The installation area is suitable for the machine, considering a minimum of 75cm for operation.
- The installation floor is solid and preferably antistatic.
- The installation floor height difference does not exceed 3cm.

#### Optional:

- The ceiling is high enough to fit the **Router System**.
- The installation area is suitable for the **Sheet Feed 75** option.

### 6.3 Connections

#### 6.3.1 Electrical

Power configuration on site:

- 3 x 400V + N, 50 Hz, 30 A
- 3 x 208V + N, 60 Hz, 30A
- 3 x 230V, 50 Hz, 30 A
- Other: \_\_\_\_\_

- The installation area meets the electrical requirements according to the machine configuration and requirements.
- Cable, plug and socket are **NOT SUPPLIED** with the machine and will be provided by the end user.

#### Sheet Feed 75:

- A separate power supply point will be provided by the end user.

## 6.3.2 Pneumatic

Compressor specifications: \_\_\_\_\_

- The installation area meets the pneumatic requirements according to the machine specifications.
- Tube, connectors and compressor are **NOT SUPPLIED** with the machine and will be provided by the end user.

### Optional:

- HF Router:** The compressor is particle class 3, water class 4, oil class 3
- POT:** The compressor is able to provide 350 l/min @ 7bar.
- Sheet Feed 75:** Compressor is 7 bar (100 PSI) @ 400 l/min (14.1 cfm) and Class 4 ISO 8573-1 or additional air cleaner/dryer

## 6.3.3 PC Requirements

- A PC is **NOT SUPPLIED** with the machine and will be provided by the end user

Operating system: \_\_\_\_\_

Design software: \_\_\_\_\_

RIP software: \_\_\_\_\_

## 6.4 Installation

Projected installation date: \_\_\_\_\_

Company name: \_\_\_\_\_

Company contact email: \_\_\_\_\_

Site address: \_\_\_\_\_

\_\_\_\_\_  
\_\_\_\_\_  
\_\_\_\_\_

- A Summa trained and certified technician will be present during the complete installation.
- The future operator of the machine will be available after the installation for training.
- The environment complies with the requirements for the machine operation.



## 6.5 Extra information or requests:

---

---

---

---

## 6.6 Conformity Declaration and Signature

I hereby declare that the site preparation document has been read thoroughly and all preparatory work will be completed upon the date of installation. The necessary parts, tools and trained personnel will be available during installation and training.

Any delays caused by a unprepared installation site will be charged.

Date of site preparation: \_\_\_\_\_

### Name and Signature

Summa Certified Dealer

End user